

**24G Millimeter Wave Radar  
R24ETT2 Multi-function Radar  
Data Book v1.1**

## Directory

<b>1. Product introduction</b> .....	<b>2</b>
1.1 Product introduction .....	2
1.2 Theory of operation .....	2
1.3 Function description .....	3
1.4 Applications .....	3
<b>2. Pin parameter explanation</b> .....	<b>3</b>
2.1 Pin explanation .....	3
2.2 Serial port output parameters .....	4
2.3 Output protocol .....	5
2.4 Naming conventions of models .....	5
<b>3. Product features</b> .....	<b>5</b>
<b>4. Electrical characteristics and parameters</b> .....	<b>6</b>
4.1 Detection angle and distance .....	6
4.2 Electrical characteristics .....	6
4.3 RF performance .....	7
4.4 Parameters of antenna .....	7
4.5 Application wiring diagram .....	7
<b>5. Main functions and performance</b> .....	<b>7</b>
5.1 Radar module coverage .....	7
5.2 Main functions and performance .....	8
<b>6. Installation method and working modes</b> .....	<b>9</b>
6.1 Installation method .....	9
6.1.1 Breath and sleep detection .....	9
6.1.2 Trajectory tracking detection .....	9
6.1.3 Gesture recognition .....	10
6.2 Work modes of radar .....	10
<b>7. Related documents</b> .....	<b>10</b>
<b>8. Typical application mode</b> .....	<b>10</b>
8.1 Installation and applications in bedrooms .....	11
8.2 Healthy life applications .....	11
8.3 Applications in home automation .....	11
<b>9. Notes</b> .....	<b>11</b>
<b>10. Disclaimer</b> .....	<b>12</b>
<b>11. Copyright notice</b> .....	<b>13</b>
<b>12. Contact</b> .....	<b>13</b>
<b>13. Updates history</b> .....	<b>13</b>

**Notes:**

Click on the link or scan the QR code to make sure you're using the latest document:

[http://en.micradar.cn/go\\_file.php?id=205](http://en.micradar.cn/go_file.php?id=205)

**1. Product introduction****1.1 Product introduction**

The R24ETT2 radar module employs 24 G millimeter-wave radar technology to realize human existence sensing, breath & sleep sensing, real-time trajectory tracking, gesture recognition and other functions. The module is based on the FMCW radar system. It determines output by detailed states of people in the specific scenario such as their positions and whether they are asleep, and allows a variety of applications in combination with gesture recognition.

Radar frequency band	24G millimeter-wave radar
Number of antennas	1T4R
Detection mechanism	FMCW
Active detection	Detection of chest expansion with breath
	Distance / angle / speed measurement
Parameter settings	N/A

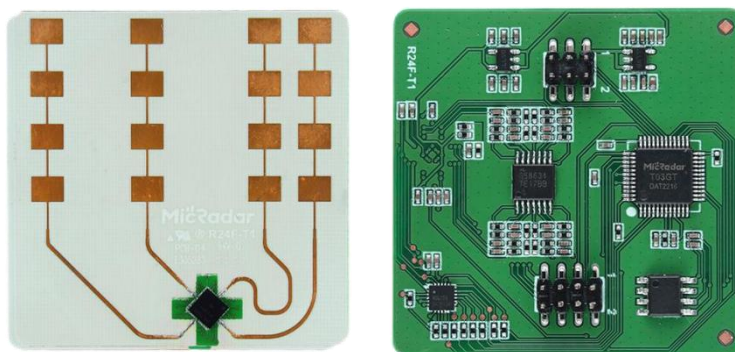

Fig. 1: Front and back sides of the radar

**1.2 Theory of operation**

The radar antenna transmits electromagnetic wave signals, and synchronically receives reflected echo signals. Then, the radar analyzes the phase difference and energy change

between waveform parameters of the echo signals from varying antennas, and gives feedback on distance, orientation, speed, subtle motion power, and other information of the target, making it possible to detect the status and trajectory of moving objects.

### 1.3 Function description

- **Motion detection amplitude:** Motion information output, such as walking and minor arm swings, can be detected within the range of the radar, upon which the human presence state will be triggered
- **Breath detection:** When someone stays still in the detection range of the radar, his / her subtle motion arising from breath, such as chest expansion, can be detected, and the state of human presence will remain.
- **Distance / angle detection:** In the detection range, the radar is able to detect the real-time change in angles and distance of a moving target, and further detect the real-time trajectory of moving people or gestures of static people based on such information.
- **Respiratory rate acquisition:** When someone stays still in the detection range of the radar, his / her subtle motion arising from breath, such as chest expansion, can be detected and summarized for outputting the respiration rate per minute.

### 1.4 Applications

- House intelligence
- Smart appliances (TVs, ACs, loudspeakers, etc.)
- Office energy conservation (ACs / lighting)
- Regional human detection
- Sleep care
- Speed / distance / orientation measurement
- Home security
- IPC triggering

## 2. Pin parameter explanation

### 2.1 Pin explanation

Interface	Pin	Description	Typical value	Notes
Interface 1	1	5V	5.0V	Power input positive
	2	GND		Ground

	3	RX	3.3v	Serial port reception
	4	TX	3.3v	Serial port send
	5	GP2	3.3V/0V	Presence / Non-presence
	6	GP1	3.3V/0V	Active / Still
Interface 2	1	3V3	3.3V	Power input positive
	2	GND		Ground
	3	SC		Reserved I/O
	4	SD		Reserved I/O
	5	GP3		Spare extension pin
	6	GP4		Spare extension pin
	7	GP5		Spare extension pin
	8	GP6		Spare extension pin

Note: 1) GP3 - GP6 are control ends of parameter selection, and can be redefined as required by the user.

2) The output signals from this interface are all 3.3 V in level.

## 2.2 Serial port output parameters

- Presence / Non-presence
- Active / Still
- Physical sign parameter
- Real-time orientation data (x, y)
- Gesture recognition
- In / Out of bed
- Sleep status: Awake / Light Sleep / Deep Sleep
- Sleep score
- Sleep quality analysis
- Respiratory rate
- Respiratory waveform
- Heartbeat frequency
- Heartbeat waveform

- Product Info

## 2.3 Output protocol

- Standard serial port protocol

## 2.4 Naming conventions of models

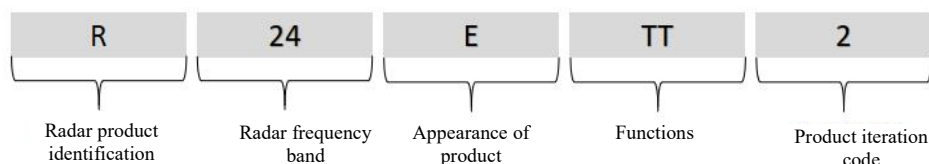

Fig. 2 Naming conventions of models

## 3. Product features

Based on the 2T2R antenna form, the R24ETT2 radar module employs a linear array equivalent to 1T4R arrays to enhance the capability of horizontal orientation measurement as well as the precision and resolution of angles in horizontal detection. This module is mainly applicable to horizontal mounting cases. It controls detection range through algorithms and secure high-precision analysis on body orientation and vital signs.

This radar module features the following:

- Realizing radar detection through FWCW (frequency modulated continuous wave);
- Tracks trajectories of multiple targets in real time;
- Recording history of sleep quality;
- Detecting vital signs of human bodies;
- Realizing double-clap gesture recognition;
- Limiting detection to humans that bear biological features (moving or static) while eliminating the interference from other inanimate objects in the same place;
- The module is capable of eliminating interference from inanimate objects as well as realizing detection of inanimate moving objects;
- The product supports secondary development, making it applicable to a variety of scenarios;
- Universal UART communication interface, with universal protocol provided
- 4 sets of I/O are reserved, allowing the user to define input and output as needed or perform simple interface simulation

- An output power no greater than 0.5 W for radar module, applicable to tasks requiring long-term power supply;
- The module is immune to temperature, lighting, dust and other factors while bearing high sensitivity, making it applicable in a variety of scenarios.

## 4. Electrical characteristics and parameters

### 4.1 Detection angle and distance

Parameter details	Minimum	Typical value	Maximum	Unit	Installation method
R24ETT2					
Human trajectory and tracking distance	-	5	5	m	Horizontal mounting
Number of tracking	-	-	3	Persons	Horizontal mounting
Detection angle of trajectory	-	-	100	Degree(s)	Horizontal mounting
Detection distance of gesture	0.5	-	2	m	Horizontal mounting
Detection angle of gesture	-	-	20	Degree(s)	Horizontal mounting
Detection angle of human presence	-	-	100	Degree(s)	Horizontal mounting
Detection distance of human presence	-	-	5	m	Horizontal mounting
Detection distance of breath and sleep	0.5	-	5	m	Inclined installation
Detection angle of breath and sleep	-	-	20	Degree(s)	Horizontal mounting

### 4.2 Electrical characteristics

Working Parameters	Minimum	Typical value	Maximum	Unit
Working voltage (VCC)	5.0	5.0	6	V

Working current (ICC)		100		mA
Working temperature (TOP)	-20	-	+85	°C
Storage temperature (TST)	-40	-	+85	°C

### 4.3 RF performance

Transmission parameter	Minimum	Typical value	Maximum	Unit
Working frequency (fTX)	24.0	-	24.25	GHz
Transmission power (Pout)	-	6	8	dBm

### 4.4 Parameters of antenna

Parameters of antenna	Minimum	Typical value	Maximum	Unit
Antenna gain ( $G_{ANT}$ )	-	10	-	dB <sub>i</sub>
Horizontal beam (3 dB)	-	100	-	°
Vertical beam (3 dB)	-	60	-	°

### 4.5 Application wiring diagram

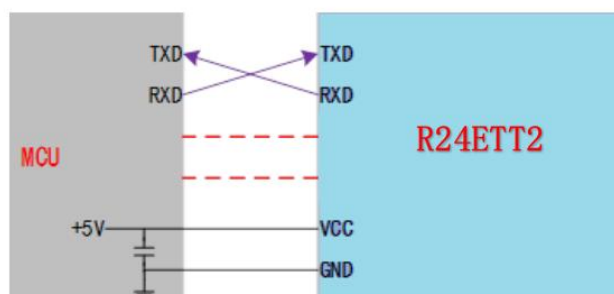

Fig. 3 Schematic diagram for connection between radar module and peripherals

## 5. Main functions and performance

### 5.1 Radar module coverage

The beam coverage of the R24EET2 radar module is shown in Fig. 4. The coverage of the radar is a three-dimensional sector 100° horizontally and 60° vertically.



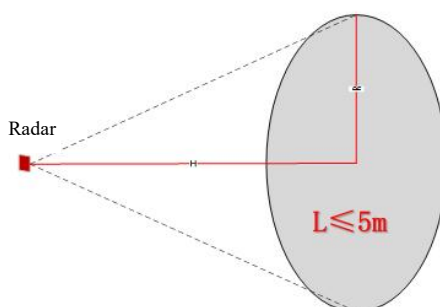

**Note: L is the furthestmost detection distance for trajectory tracking**

Fig. 4 Diagram for coverage of radar beams

Affected by the characteristics of radar beams, the operating distance along the normal line to the antenna face is greater, while the one displacing from it is smaller.

Attention should be paid that when the radar is of horizontal mounting, the range of the radar will be reduced as a result of radar beam coverage and effective radiation space.

## 5.2 Main functions and performance

### ➤ Sleep detection

- Distance of detection:  $\leq 5$  m (detection distance between people and the face of radar antenna)
- Sleep quality assessment: Awake / Light Sleep / Deep Sleep
- Sleep time recording: Temporal data output on sleep quality
- In bed state: In / Out of bed

### ➤ Breath detection

- Distance of detection:  $0.4 \text{ m} \leq x \leq 5 \text{ m}$  (detection distance between chest and the face of radar antenna)
- Accuracy: (When the distance is no greater than 1.5 m under static state) accuracy  $\geq 85\%$

### ➤ Heartbeat detection

- Distance of detection:  $0.4 \text{ m} \leq x \leq 5 \text{ m}$  (detection distance between chest and the face of radar antenna)
- Accuracy: (When the distance is no greater than 1.5 m under static state) accuracy  $\geq 80\%$

### ➤ Presence sensing

- Distance of detection:  $\leq 5$  m (detection distance between people and the face of radar antenna)
- Accuracy:  $\geq 90\%$

- Trajectory tracking detection
  - a. Distance of detection:  $\leq 5$  m (detection distance between people and the face of radar antenna)
  - b. Accuracy:  $\geq 90\%$

## 6. Installation method and working modes

### 6.1 Installation method

Mounting method for this radar module should be selected in accordance with function applications.

#### 6.1.1 Breath and sleep detection

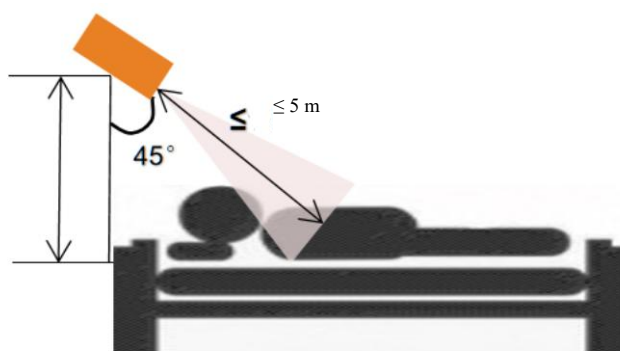

Fig. 5 Diagram for inclined mounting

#### 6.1.2 Trajectory tracking detection

As shown in Fig. 6, it's recommended to install the radar horizontally and laterally at a height of 1.3 - 1.5 m, with the normal line of the radar aligned with the main point of detection. The trajectory detection area should be clear, and the detection distance  $L \leq 5$  m between people and radar antenna face (so that the radar can reliably detect the trajectory of people)

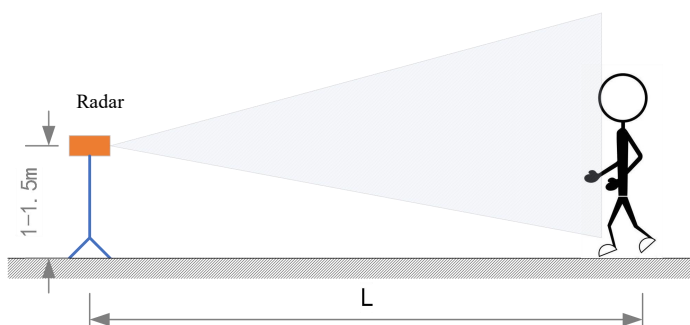

Fig. 6 Diagram of horizontal mounting

### 6.1.3 Gesture recognition

It's recommended to install the radar horizontally and laterally (see Fig. 6) at a height of 1.3 - 1.5 m, with the normal line of the radar aligned with the main point of detection. The detection areas for both trajectories and gestures should be clear, and the detection distance  $0.5 \text{ m} \leq L \leq 2 \text{ m}$  between people and radar antenna face (so that the radar can reliably detect the gestures of people)

## 6.2 Work modes of radar

Upon statistical analysis, the radar module will perform a comprehensive assessment over the states of persons in current detection area, results of which are readily usable by the user.

### Sleep and breath detection mode

In this mode, the radar module periodically gives feedback on the sleep status and respiratory rate of persons in current detection area, which mainly include:

- Sleep quality assessment: Awake / Deep Sleep / Light Sleep;
- In / Out of bed judgement;
- Breath / heart rate frequency statistics;
- In order to ensure accurate judgement on sleep-related states in sleep detection mode, having people covered in the range of sleep and breath detection should be taken into account for installation;

### Trajectory tracking detection mode

In this mode, the radar module periodically gives feedback on the trajectory and orientation of persons in current detection area, which mainly include:

- Real-time orientation information: (x, y);

### Gesture recognition detection mode

In this mode, the radar module will detect in real time the occurrence of motion that matches gesture judgement conditions, upon which a message of gesture recognition success will be given. Below are the main states:

- Gesture recognition success state;

## 7. Related documents

- User Manual: To be updated

## 8. Typical application mode

This module is mainly applicable to scenarios such as health management or home powering. Below are the details on the applications in typical scenarios.

## 8.1 Installation and applications in bedrooms

To give relevant information on people lying in bed in certain cases, e.g. presence / non-presence, sleep states, depth of sleep, motion information, etc., so as to realize specific applications. Applications realizable based on this mode include

- Care for the aged
- Health care
- Home automation
- Home health

## 8.2 Healthy life applications

Based on the detection features on sleep states and respiratory rate of sleeping people, this radar is quite applicable to healthy life scenarios, which include:

- Linkage to intelligent health products
- Appliance powering

## 8.3 Applications in home automation

Based on the real-time trajectory tracking detection, this radar is quite applicable to home automation linkages, which include:

- Lighting follow-up for smart lamps
- Wind follow-up for ACs

Based on the gesture recognition detection, this radar is quite applicable to home automation linkages, which include:

- Switching on / off appliances by gesture

## 9. Notes

### 9.1 Start-up time

The module needs to fully reset its internal circuits and performs a full assessment on ambient noise when it is powered on and starts to work, so as to ensure the module can work properly. As a result, the module requires a stabilizing time  $\geq 30$  s upon powering on to ensure the effectiveness of parameters output subsequently.

### 9.2 Limits on breath & heartbeat detection scenarios

The radar is a kind of non-contact devices. To detect the breath and heartbeat of the target, it needs to lock the position of the target before collecting and calculating the intensity and

values of breath and heartbeat of the target. On this account, the target detection should be in appropriate detection range and should stay still to avoid influencing on locking by the radar and thus on breath and heartbeat detection.

### **9.3 Effective distance of detection**

The distance of detection of the radar module depends mainly on target RCS and environmental factors, and might vary with the environment and the target. This module is not provided with distance measurement feature for now, and hence it's normal for the effective distance of detection to fluctuate in a certain range.

### **9.4 Bio-detection performance of radar**

Due to the fact that the biological features of human bodies are characteristic signals of super low frequency and weak reflection, long-period accumulation is required for radar processing. However, a number of factors might affect the parameters of the radar during the course. On this account, it's normal that detection fails sporadically.

### **9.5 Power source**

The radar module has requirements higher than regular low-frequency circuits on power source quality. When supplying power to the module, the power source is required to be free from any threshold glitches or ripples, and can effectively shield power supply noise from accessories.

The radar module requires proper grounding. Ground noise from other circuits might compromise the performance or even cause an anomaly in the module. A reduced distance of detection or increased false alarm rate is one of the commonest.

To ensure the VCO circuit inside the module works properly, power supply to this module should be +5V - +6V, with ripple voltage  $\leq 100$  mV.

External power supply must be able to provide sufficient current output and transient response capacity.

## **10. Disclaimer**

To our best knowledge, the description in the document is accurate when it was released. Considering the technical complexity of products and the differences in working environments, it's impracticable to eliminate each and every inaccurate or imperfect description. On this account, this document is for reference by the user only. We reserve the right to make any changes to the product without a prior notice to the user. We make no commitments nor guarantees on the legal level. We encourage the customers to give valuable opinions on the latest update on the product and its supportive tools.

## 11. Copyright notice

All elements and parts mentioned herein constitute a reference to publications disclosed by the corresponding copyright holders, who shall reserve the rights to modify and publish the same. Please confirm the updates and corrigenda of such information via appropriate channels prior to any use of them. We hold no rights and obligations as for these publications.

## 12. Contact

Yunfan Ruida Technology (Shenzhen) Co., Ltd.

Email: [sales@micradar.cn](mailto:sales@micradar.cn).

Telephone: 0755-88602663

Address: 501, West Block, Tian'an Innovation Technology Plaza (Phase 2), Futian District, Shenzhen, Guangdong Province

## 13. Updates history

Revision	Release Data	Summary	Author
V1.0_0215	2/15/2023	First draft	Mark
V1.1_0309	3/9/2023	Adjusted the composition of the front portion of the document	Mark