

**60G millimeter-wave radar
R60BFD1 Fall alarm radar
Data Book v1.1**

Contents

1. Product introduction	2
1.1 Product introduction	2
1.2 Theory of operation	2
1.3 Function description	3
1.4 Parameter settings	3
1.5 Applications	3
2. Product encapsulation diagram	3
3. Pin parameter explanation	4
3.1 Pin explanation	4
3.2 Serial port output parameters	4
3.3 Settable parameters	5
3.4 Output protocol	5
3.5 Naming conventions of models	5
4. Product features	5
5. Electrical characteristics and parameters	6
5.1 Detection angle and distance	6
5.2 Electrical characteristics	6
5.3 Parameters of antenna	7
5.4 Transmission parameters	7
5.5 Application wiring diagram	7
6. Main functions and performance	7
6.1 Radar module coverage	7
6.2 Main functions and performance	8
7. Installation method and working modes	9
7.1 Top mounting	9
7.2 Typical applications	9
8. Notes	10
8.1 Start-up time	10
8.2 Effective distance of detection	10
8.3 Bio-detection performance of radar	10
8.4 Power source	10
9. FAQs	10
10. Disclaimer	11
11. Copyright notice	11
12. Contact	11
13. Revision History	11

Notes:

Click on the link or scan the QR code to make sure you're using the latest document:

http://en.micradar.cn/go_file.php?id=182

1. Product introduction

1.1 Product introduction

The R60BFD1 radar module employs the 60G millimeter-wave radar technology to sense human body motions and postures, thereby realizing fall monitoring. Based on the FMCW radar system, the module can realize wireless sensing of personal status in specific places, and timely report fall states of people, or stay-still alarms upon prolonged state of remaining still.

Radar frequency band	60G millimeter-wave radar
Number of antennas	4T4R
Detection mechanism	FMCW
Active detection	Chest expansion with breath, human existence
	Motion change and posture recognition
Parameter settings	Height settings
	Fall report time settings, stay-still alarm report time settings



Fig. 1: Front and back sides of the radar

1.2 Theory of operation

The radar antenna transmits electromagnetic wave signals, and synchronically receives reflected echo signals. Then, the radar analyzes the phase difference and energy change between waveform parameters of the echo signals from varying antennas, and gives feedback on distance, orientation, speed, motion power, and other information of the target, making it possible to detect postures of people.

1.3 Function description

- Motion detection amplitude: Motion information output, such as walking and minor arm swings, can be detected within the range of the radar, upon which the human presence state will be triggered.
- Breath detection: When someone stays still in the detection range of the radar, his/her subtle motion arising from breath, such as chest expansion, can be detected, and the state of human presence will remain.
- Posture recognition: In the detection range, the radar is able to detect the real-time change in point cloud, distance and speed a moving target, and further detect the posture and etc. of people based on such information.

1.4 Parameter settings

- Height settings: Height should be set for actual mounting and use of the radar. The actual height of mounting should be the same as the underlying settings (2 m by default)
- Fall report time settings: The default of fall report time is 30 s. When the radar detects a fall of someone, the detection will last for a while (adjustable in 5 - 180 s). A value less than 30 s can be used for demonstration purpose, while for normal projects, a value greater than 60 s is recommended.
- Stay-still alarm report time settings: The default for stay-still time is 300 s. When the radar detects a person staying still for a period of time (settable), it will report a stay-still alarm. For normal projects, a value of greater than 30 min. is recommended.

1.5 Applications

- Smart care (kitchens and bathrooms)
- House intelligence
- Home security

2. Product encapsulation diagram

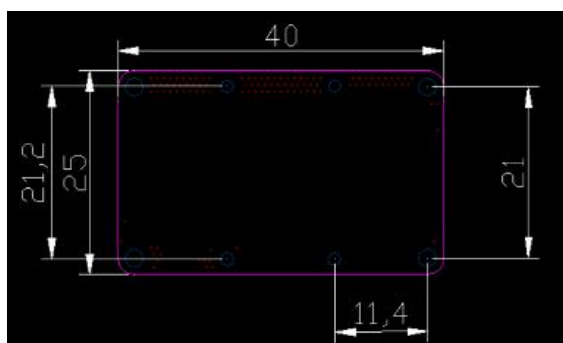
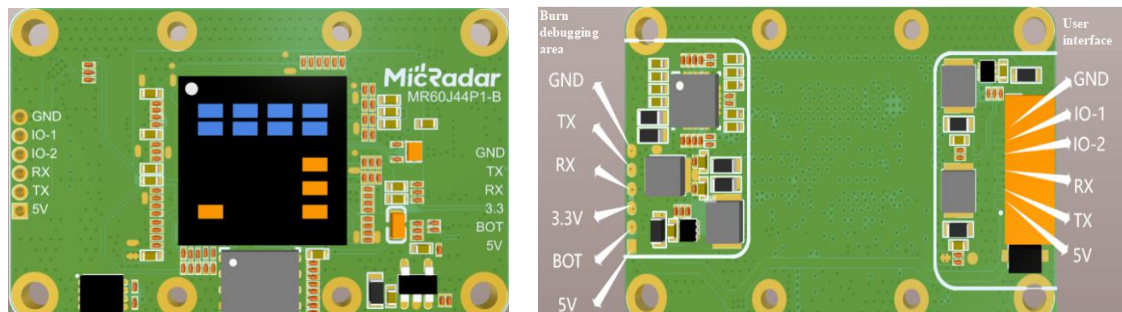

Fig. 2: Schematic diagram for radar module frame

- Volume: 40mm×25mm
- Interface: 6PIN female terminal (spacing: 1.25mm)

3. Pin parameter explanation



3.1 Pin explanation

Interface	Pin	Description	Typical value	Notes
Interface 1	1	GND	0V	Ground
	2	IO-1	3.3V/0V output	Presence/Non-presence
	3	IO-2	3.3V/0V output	Fall alarm/Clear alarm
	4	RX	3.3V TTL level	Serial port reception
	5	TX	3.3V TTL level	Serial port send
	6	5V	5V	Input power source
Interface 2	1	GND	0V	Ground
	2	TX	3.3V TTL level	Serial port send
	3	RX	3.3V TTL level	Serial port reception
	4	3V3	3.3V	Input power source
	5	BOOT	Suspension by default	Burning guide pin
	6	5V	5V	Input power source

3.2 Serial port output parameters

- Presence/Non-presence
- Fall state
- Body movement parameter 0 - 100
- Stay-still (report time settable)

3.3 Settable parameters

- Mounting height
- Stay-still time settings
- Fall/Stay-still switch

3.4 Output protocol

- Standard serial port protocol

3.5 Naming conventions of models

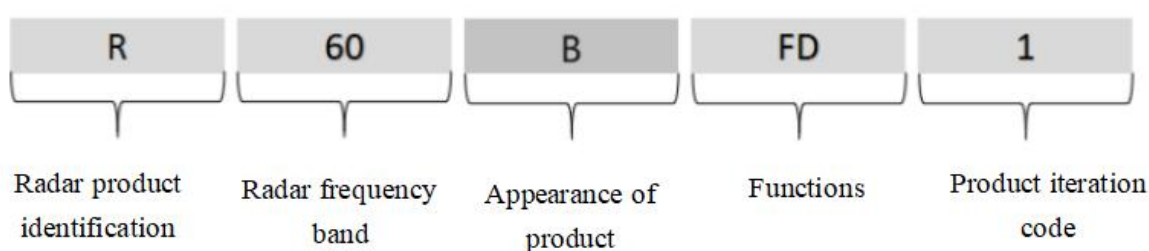

Fig. 3: Naming conventions of models

4. Product features

The R60BFD1 radar module is in the form of 4 transmit and 4 receive antenna elements: With the planar antenna array layout, it can detect the distances and angles in 2D and 3D spaces. It is mainly suitable for inclined installation, to detect falls of people within the coverage of a certain angle and accurately scan the full-body tomography, so as to realize fall detection of different height and varying speed of human bodies.

This radar module features the following:

- Realizing synchronous sensing on people who are moving and staying still (sitting still or sleeping);
- Realizing fall detection;
- Detecting different motion amplitudes, and outputting values and states in real time
- The targets of detection are humans that bear biological features (moving or static), with the interference from other inanimate objects in the same place eliminated;
- The module is capable of eliminating interference from inanimate objects as well as realizing detection of inanimate moving objects;
- The product supports secondary development, making it applicable to a variety of

scenarios;

- Universal UART communication interface, with universal protocol provided;
- I/O interface, allowing the user to define input and output as needed or perform simple interface simulation;
- Of small output power and hence harmless to health;
- The module is immune to temperature, lighting, dust and other factors while bearing high sensitivity, making it applicable in a variety of scenarios.

5. Electrical characteristics and parameters

5.1 Detection angle and distance

Parameter details	Minimum	Typical value	Maximum	Unit
Moving target detection				
Distance to trigger motion detection	-	-	5	m
Distance precision	-	-	0.08	m
Angle of horizontal detection of radar	-	-	±50	°
Angle of vertical detection of radar	-	-	±40	°
Angle precision	-	-	10	°
Static target detection				
Distance of staying still detection	-	-	3	m
Distance precision	-	-	0.3	m
Angle of horizontal detection of radar	-	-	±40	°
Angle of vertical detection of radar	-	-	±30	°
Fall detection				
Fall detection distance [1]	-	3	3	m
Horizontal angle of fall detection [2]	-	-	±30	°

Note: [1] [2] Radar projection diameter at a height of 2m and inclination of 30°.

5.2 Electrical characteristics

Parameter details	Minimum	Typical value	Maximum	Unit
Working voltage (VCC)	-	5.0	6	V
Working current (ICC)	-	500	600	mA
Working temperature (TOP)	-20	-	+65	°C
Humidity	-	-	80%	No condensation
Storage temperature (TST)	-40	-	+105	°C

5.3 Parameters of antenna

Parameter details	Minimum	Typical value	Maximum	Unit
Antenna gain (G_{ANT})	62	-	64	GHz
Horizontal beam (3 dB)	-	100	-	°
Vertical beam (3 dB)	-	80	-	°

5.4 Transmission parameters

Parameter details	Minimum	Typical value	Maximum	Unit
Working frequency (fTX)	62	-	64	GHz
Transmission power (Pout)	-	6	8	dBm

5.5 Application wiring diagram

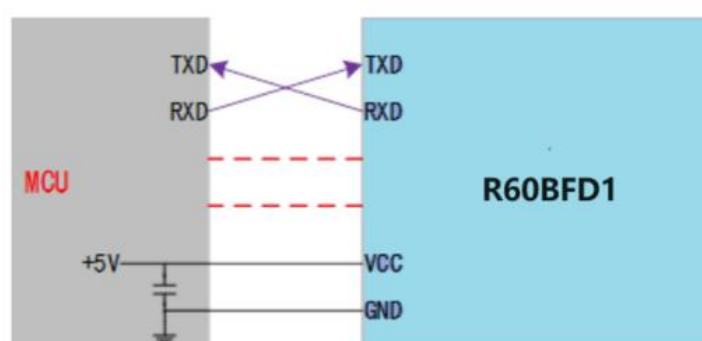
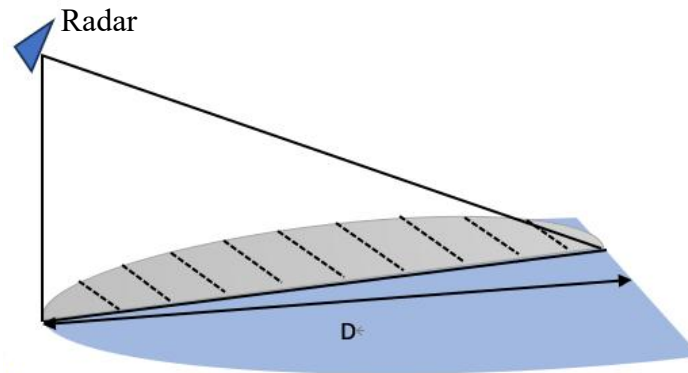

Fig. 4: Schematic diagram for connection between radar module and peripherals

6. Main functions and performance

6.1 Radar module coverage

The radar module is installed in a tilting way, and its beam coverage is shown in Fig. 5. The coverage of the radar is a three-dimensional sector 90° horizontally and 60° vertically.



D = 3m (detection distance of radar)

Fig. 5 Coverage of radar

Affected by the characteristics of radar beams, the operating distance along the normal line to the antenna face is greater, while the one displacing from it is smaller.

Attention should be paid that when the radar is top-mounted, the range of the radar will be reduced as a result of radar beam coverage and effective radiation space.

6.2 Main functions and performance

The main functions of this radar module include:

- Fall detection
 - a. Distance of detection: $\leq 4\text{m}$ (radar projection diameter when the radar module is suspended in a tilted way)
 - b. Accuracy: $\geq 95\%$
- Stay-still detection
 - a. Distance of detection: $\leq 4\text{m}$ (radar projection diameter when the radar module is suspended in a tilted way)
 - b. Accuracy: $\geq 99\%$
- Presence sensing
 - a. Distance of detection: $\leq 4\text{m}$ (radar projection diameter when the radar module is suspended in a tilted way)
 - b. Accuracy: $\geq 99\%$
- Motion detection

- a. Range of motion triggering: $\leq 5\text{m}$ (The default value is 4m, the projection diameter of the radar when it is installed at an angle)
- b. Motion orientation and position sensing

7. Installation method and working modes

7.1 Top mounting

The radar is wall-mounted and tilted downward for detection.

The mounting height of the radar is $H = 1.8\text{ m}$ (Other heights may be accommodated in the future). The diameter of radar beam coverage is R . The zone of radar projection is considered to be further divided into the fall detection zone, stay-still detection zone, presence detection zone, and motion triggering detection zone, as shown below in Fig. 6.

Depending on the height of mounting and beam coverage, in this mounting mode, the max. diameter of fall/stay-still detection is $D1 \leq 4\text{ m}$, static presence $D2 \approx 4\text{ m}$, and motion detection $D3 \approx 3\text{ m}$.

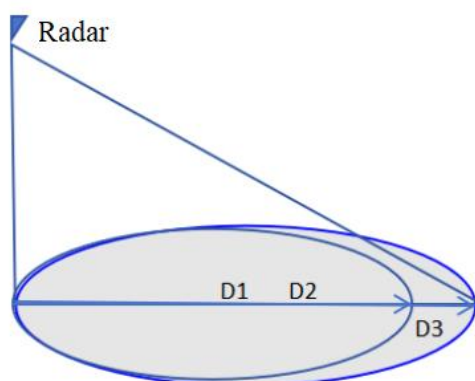

Fig. 6 Diagram of Radar Projection

7.2 Typical applications

- The product is applicable to scenarios of a small area, such as bathrooms, toilets, kitchens, etc.
- This product is suitable for hanging in a tilted way.
- The product is applicable to cases involving a single person.
- The product needs to take into account the scene of applications to eliminate motion interference.

8. Notes

8.1 Start-up time

The module needs to fully reset its internal circuits and performs a full assessment on ambient noise when it is powered on and starts to work, so as to ensure the module can work properly. As a result, the module requires a stabling time ≥ 15 s upon powering on to ensure the effectiveness of parameters output subsequently.

8.2 Effective distance of detection

The distance of detection of the radar module depends mainly on target RCS and environmental factors, and might vary with the environment and the target. This module is not provided with distance measurement feature for now, and hence it's normal for the effective distance of detection to fluctuate in a certain range.

8.3 Bio-detection performance of radar

Due to the fact that the biological features of human bodies are characteristic signals of super low frequency and weak reflection, long-period accumulation is required for radar processing. However, a number of factors might affect the parameters of the radar during the course. On this account, it's normal that detection fails sporadically.

8.4 Power source

The radar module has requirements higher than regular low-frequency circuits on power source quality. When supplying power to the module, the power source is required to be free from any threshold glitches or ripples, and can effectively shield power supply noise from accessories.

The radar module requires proper grounding. Ground noise from other circuits might compromise the performance or even cause an anomaly in the module. A reduced distance of detection or increased false alarm rate is one of the commonest.

To ensure the VCO circuit inside the module works properly, power supply to this module should be +5V - +6V, with ripple voltage ≤ 100 mV.

External power supply must be able to provide sufficient current output and transient response capacity.

9. FAQs

- Interference factors: The radar is a sensor for electromagnetic wave detection. Inanimate objects that are moving can lead to a false alarm. Movements of metal and liquid can lead to misjudgment. Normally, fans, pets close to the radar, and waving of metallic curtains can lead to misjudgment. Installation angle should be properly designed for the radar.

- Non-interference factors: Electromagnetic waves of the radar can penetrate clothes, curtains, thin wooden boards, and glass. On this account, installation angle and performance should be determined according to applications.
- Quasi-interference factors: The radar should not face an AC directly if it's to detect human presence. The internal motor of ACs can lead to misjudgment. Therefore, it's required that the radar product is not installed facing an AC directly or in the same orientation as an AC.

10. Disclaimer

To our best knowledge, the description in the document is accurate when it was released. Considering the technical complexity of products and the differences in working environments, it's impracticable to eliminate each and every inaccurate or imperfect description. On this account, this document is for reference by the user only. We reserve the right to make any changes to the product without a prior notice to the user. We make no commitments nor guarantees on the legal level. We encourage the customers to give valuable opinions on the latest update on the product and its supportive tools.

11. Copyright notice

All elements and parts mentioned herein constitute a reference to publications disclosed by the corresponding copyright holders, who shall reserve the rights to modify and publish the same. Please confirm the updates and corrigenda of such information via appropriate channels prior to any use of them. We hold no rights and obligations as for these publications.

12. Contact

Yunfan Ruida Technology (Shenzhen) Co., Ltd.

Email: sales@micradar.cn.

Telephone: 0755-88602663

Address: 501, West Block, Tian'an Innovation Technology Plaza (Phase 2), Futian District, Shenzhen, Guangdong Province

13. Revision History

Revision	Release Data	Summary	Author
V1.0	2023/10/30	First draft	Jason
V1.1	2024/04/03	Fixed some parameters	OF_Frank