

60G millimeter-wave radar
R60ATT1
Multi-Person Trajectory Radar
Data Book v1.1

Contents

1. Product introduction	2
1.1 Product introduction	2
1.2 Theory of operation	2
1.3 Function description	2
1.4 Applications	3
2. Product encapsulation diagram	3
3. Parameter description	3
3.1 Serial port output parameters	3
3.2 Output protocol	4
3.3 Naming conventions of models	4
4. Product features	4
5. Electrical characteristics and parameters	5
5.1 Detection angle and distance	5
5.2 Electrical characteristics	5
5.3 RF performance	5
5.4 Application wiring diagram	6
6. Main functions and performance	6
6.1 Radar module coverage	6
6.2 Main functions and performance	7
7. Installation method and working modes	7
7.1 Installation method	7
7.2 Work modes of radar	8
8. Related documents	8
9. Typical application mode	9
9.1 Applications in smart appliances	9
9.2 Security management	9
10. Notes	9
10.1 Start-up time	9
10.2 Effective distance of detection	9
10.3 Bio-detection performance of radar	9
10.4 Power source	10
11. Disclaimer	10
12. Copyright notice	10
13. Contact	10
14. Revision History	10

Notes:

Click on the link or scan the QR code to make sure you're using the latest document:

http://en.micradar.cn/go_file.php?id=164

1. Product introduction

1.1 Product introduction

The R60ATT1 radar module employs the millimeter-wave radar technology to realize distance, angle and speed sensing of human motion. Based on the 1T3R FMCW (frequency modulated continuous wave) signal processing mechanism, this module performs real-time trajectory tracking on multiple targets in the detection range of specific areas via the synchronous sensing technology that detects motion orientation and chest expansion parameters, and is able to lock the coordinates of static persons.

Radar frequency band	60G millimeter-wave radar
Number of antennas	1T3R
Detection mechanism	FMCW
Active detection	Detection of chest expansion with breath
	Distance / angle / speed measurement
Parameter settings	N/A



Fig. 1: Front and back sides of the radar

1.2 Theory of operation

The radar antenna transmits electromagnetic wave signals, and synchronically receives reflected echo signals. Then, the radar analyzes the phase difference and energy change between waveform parameters of the echo signals from varying antennas, and gives feedback on distance, orientation, speed, motion power, and other information of the target. making it possible to detect the status and trajectory of moving objects.

1.3 Function description

- Motion detection amplitude: Motion information output, such as walking and minor arm swings, can be detected within the range of the radar, upon which the human presence state will be triggered
- Breath detection: When someone stays still in the detection range of the radar, his / her subtle motion arising from breath, such as chest expansion, can be detected, and the state of human presence will remain.
- Distance / angle detection: In the detection range, the radar is able to detect the real-time change in angles and distance of a moving target, and further detect the real-time trajectory of moving people based on such information.

1.4 Applications

- House intelligence
- Smart appliances (TVs, ACs, loudspeakers, etc.)
- Office energy conservation (ACs / lighting)
- Regional human detection
- Speed / distance / orientation measurement
- Home security
- IPC triggering

2. Product encapsulation diagram

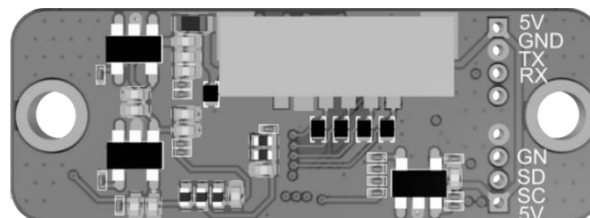

Fig. 2: Schematic diagram for radar module frame

- Volume: 33mm×12mm
- Interface: 7 pin vertical power strip connector. 2 connectors in total: 2*3 and 2*4

3. Parameter description

3.1 Serial port output parameters

- Presence / Non-presence
- Active / Still
- Physical sign parameter

- Real-time orientation data (x, y)
- Product Info

3.2 Output protocol

- Standard serial port protocol
- Standard protocol of Tuya

3.3 Naming conventions of models

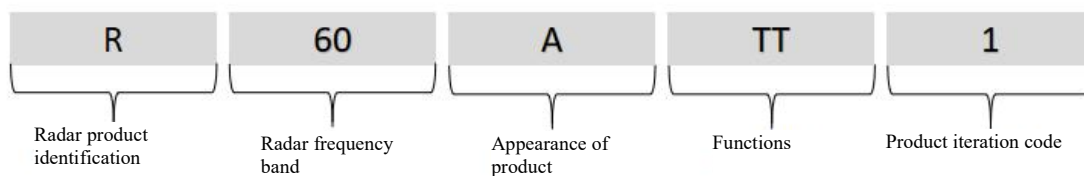

Fig. 3: Naming conventions of models

4. Product features

The R60ATT1 radar module is in the form of 1 transmit and 3 receive antenna elements: the wide-beam radar module controls the angle to a certain range via algorithms, scans accurately the real-time changes in orientation and distance of multiple targets, and refreshes the 3D data (X/Y/Z) of these targets in real time.

This radar module features the following:

- Realizing radar detection through FWCW (frequency modulated continuous wave);
- Tracks trajectories of multiple targets in real time;
- Max. detection distance of motion trajectory tracking: ≤ 5 m (horizontal-mounted);
- Max. detection distance of static position locking: ≤ 4 m (horizontal-mounted);
- Max. number of multi-target trajectory tracking: ≤ 3 persons;
- Min. angle resolution for multi-target motion trajectory tracking: $\geq 56^\circ$;
- Min. distance resolution for multi-target motion trajectory tracking: ≥ 0.5 m;
- Max. angle of horizontal detection for multi-person trajectory tracking: $\leq 100^\circ$;
- Limiting detection to humans that bear biological features (moving or static) while eliminating the interference from other inanimate objects in the same place;
- The module is capable of eliminating interference from inanimate objects as well as realizing detection of inanimate moving objects;
- The product supports secondary development, making it applicable to a variety of

scenarios;

- Universal UART communication interface, with universal protocol provided
- An output power no greater than 0.5 W for radar module, applicable to tasks requiring long-term power supply;
- The module is immune to temperature, lighting, dust and other factors while bearing high sensitivity, making it applicable in a variety of scenarios.

5. Electrical characteristics and parameters

5.1 Detection angle and distance

Parameter details	Minimum	Typical value	Maximum	Unit	Installation method
R60ATT1					
Mounting height of radar	1.0	1.4	1.5	m	Horizontal mounting
Human trajectory and tracking distance	-	-	5	m	Horizontal mounting
Sensing distance for positions of static persons	-	-	4	m	Horizontal mounting
Number of tracking	-	-	3	Persons	Horizontal mounting
Angle of radar detection (horizontal)	-	100	-	Degree(s)	
Angle of radar detection (inclined)	-	100	-	Degree(s)	

5.2 Electrical characteristics

Working Parameters	Minimum	Typical value	Maximum	Unit
Working voltage (VCC)	4.5	5.0	6	V
Working current (ICC)	90	93	100	mA
Working temperature (TOP)	-20	-	+60	°C
Storage temperature (TST)	-40	-	+105	°C

5.3 RF performance

Transmission parameter	Minimum	Typical value	Maximum	Unit
Working frequency (fTX)	61	-	61.5	GHz
Transmission power (Pout)	-	-	6	dBm

5.4 Application wiring diagram

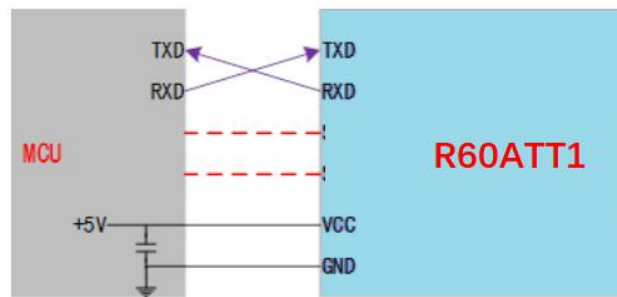
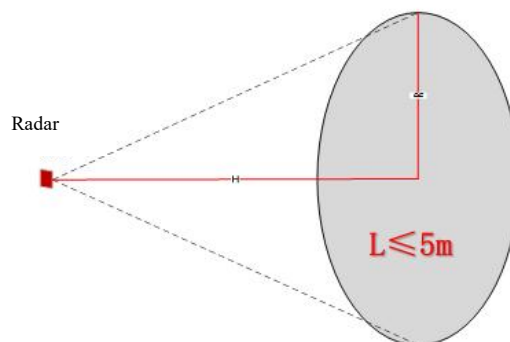

Fig. 4: Schematic diagram for connection between radar module and peripherals

6. Main functions and performance

6.1 Radar module coverage

The beam coverage of the radar module is shown in Fig. 5. The coverage of the radar is a three-dimensional sector 100° horizontally and 100° vertically.



Note: L is the furthestmost detection distance for trajectory tracking

Fig. 5 Coverage of radar

Affected by the characteristics of radar beams, the operating distance along the normal line to the antenna face is greater, while the one displacing from it is smaller.

Attention should be paid that when the radar is top-mounted, the range of the radar will be reduced as a result of radar beam coverage and effective radiation space.

6.2 Main functions and performance

The main functions of this radar module include:

- Motion detection (laterally facing human bodies)
 - a. Max. sensing distance for motion: 6 m (common motion amplitude of adults);
 - b. Triggering time for motion: ≤ 0.5 s;
- Static state detection (laterally facing human bodies)
 - a. Sensing distance for static human bodies: 4 m;
 - b. Time of detection for non-presence: ≤ 40 s;
- Real-time tracking and detection of multi-person trajectories
 - a. Max. tracking distance of motion trajectories: 5 m (moving radially to / from radar);
 - b. Max. detection distance of static positions: 4 m;
 - c. Distance resolution ≤ 0.5 m;
 - d. Precision of distance measurement: ≤ 0.3 m;
 - e. Precision of angle measurement: $\leq 5^\circ$; (target ≥ 2 m)
 - f. Refresh rate of motion detection: ≥ 10 Hz;
 - g. Max. number of trajectory tracking: 3;
 - h. Min. angle for target distinction in multi-person trajectory tracking: $\geq 56^\circ$;
(horizontal-mounted)
 - i. Min. distance for target distinction in multi-person trajectory tracking: ≥ 0.5 m;
(horizontal-mounted)

7. Installation method and working modes

7.1 Installation method

This radar module is recommended to be mounted horizontal.

Figure 6 shows the horizontal mounting method, which applies to position detection of walking or seated targets, such as living rooms, electrical appliances, etc.

The radar is recommended to be installed at a height of 1 m - 1.5 m, horizontally in forward direction, with a tilt $< \pm 5^\circ$.

The front of the radar should not be blocked or covered whatsoever.

The normal line of the radar should be aligned with the main point of detection to ensure the main beam of the radar antenna covers the detection area and the airspace of body activities.

Under this installation mode, the max. distance of trajectory tracking for moving targets is $L1 \leq 5$ m; the max. distance of position detection for static targets is $L2 \leq 4$ m; and the min. distinguishing angle / distance is $56^\circ/0.5$ m for simultaneous detection of multiple targets.

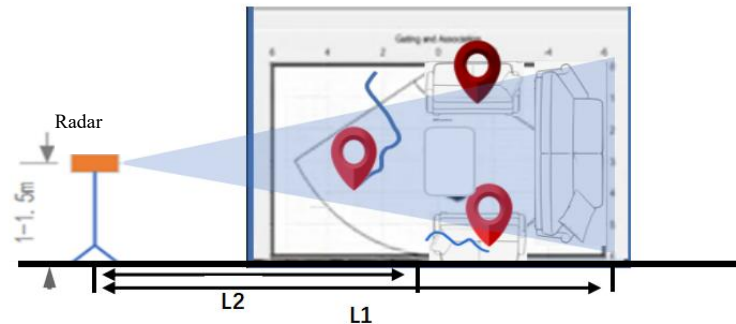

Fig. 6 Horizontal mounting diagram

7.2 Work modes of radar

Upon statistical analysis, the radar module will perform a comprehensive assessment over the real-time position & states and the count of persons in current detection area, results of which are readily usable by the user.

Multi-person trajectory tracking mode

In this mode, the radar module gives real-time feedback on the variation of positions for every target in current detection area. Main states include:

- Real-time output of multi-person positions;

8. Related documents

- User Manual: Links to be updated

9. Typical application mode

This module is mainly applicable to scenarios such as home appliance powering and security management. Below are the details on the applications in typical scenarios.

9.1 Applications in smart appliances

For specific applications, the product outputs information on positions of people in real time, and fulfilled the intended purposes with the relevant data. The radar should be horizontally mounted in this mode. Applications realizable based on this mode include

- Smart fresh air systems
- Smart loudspeaker applications

9.2 Security management

For specific applications, the product outputs information on the count of people periodically, and fulfilled the intended purposes with the relevant data. The radar should be horizontally mounted in this mode. Applications realizable based on this mode include

- Personnel management in security scenarios

10. Notes

10.1 Start-up time

The module needs to fully reset its internal circuits and performs a full assessment on ambient noise when it is powered on and starts to work, so as to ensure the module can work properly. As a result, the module requires a stabling time ≥ 30 s upon powering on to ensure the effectiveness of parameters output subsequently.

10.2 Effective distance of detection

The distance of detection of the radar module depends mainly on target RCS and environmental factors, and might vary with the environment and the target. This module is not provided with distance measurement feature for now, and hence it's normal for the effective distance of detection to fluctuate in a certain range.

10.3 Bio-detection performance of radar

Due to the fact that the biological features of human bodies are characteristic signals of super low frequency and weak reflection, long-period accumulation is required for radar processing. However, a number of factors might affect the parameters of the radar during the course. On this account, it's normal that detection fails sporadically.

10.4 Power source

The radar module has requirements higher than regular low-frequency circuits on power source quality. When supplying power to the module, the power source is required to be free from any threshold glitches or ripples, and can effectively shield power supply noise from accessories.

The radar module requires proper grounding. Ground noise from other circuits might compromise the performance or even cause an anomaly in the module. A reduced distance of detection or increased false alarm rate is one of the commonest.

To ensure the VCO circuit inside the module works properly, power supply to this module should be +5V - +6V, with ripple voltage ≤ 100 mV.

External power supply must be able to provide sufficient current output and transient response capacity.

11. Disclaimer

To our best knowledge, the description in the document is accurate when it was released. Considering the technical complexity of products and the differences in working environments, it's impracticable to eliminate each and every inaccurate or imperfect description. On this account, this document is for reference by the user only. We reserve the right to make any changes to the product without a prior notice to the user. We make no commitments nor guarantees on the legal level. We encourage the customers to give valuable opinions on the latest update on the product and its supportive tools.

12. Copyright notice

All elements and parts mentioned herein constitute a reference to publications disclosed by the corresponding copyright holders, who shall reserve the rights to modify and publish the same. Please confirm the updates and corrigenda of such information via appropriate channels prior to any use of them. We hold no rights and obligations as for these publications.

13. Contact

Yunfan Ruida Technology (Shenzhen) Co., Ltd.

Email: sales@micradar.cn.

Telephone: 0755-88602663

Address: 501, West Block, Tian'an Innovation Technology Plaza (Phase 2), Futian District, Shenzhen, Guangdong Province

14. Revision History

Revision	Release Data	Summary	Author
V1.0_0215	2/15/2023	First draft	Mark
V1.1_0309	3/9/2023	Adjusted the composition of the front portion of the document	Mark