

# 60G Millimeter Wave Radar Module

**R60AFD1 Fall Detection Radar**

User manual (Ver.1.6)

# Contents

1. Product introduction .....	2
2. Theory of operation .....	2
3. Notes for hardware design .....	3
3.1 For the power supply, refer to the circuit design below .....	3
3.2 Application wiring diagram .....	3
4. Requirements for antenna and housing layout .....	4
5. Electrostatic protection .....	4
6. Function description .....	4
6.1 Description of function point .....	4
7. Protocol description .....	5
8. Definition of communication command and parameter .....	5
8.1 Definition and description of frame structure .....	5
8.2 Description of address assignment and data information .....	6
Appendix 1: Example of data instruction generation .....	11
9. Updates history .....	12

## 1. Product introduction

This document mainly describes the use of radar, the problems that may be encountered at different stages, to minimize the design costs and increase the stability of the product, and to improve the efficiency of the project.

Hardware circuit reference design, radar antenna and housing layout requirements, how to distinguish between interference and multi-functional UART protocol output.

The radar is a self-contained space sensing sensor, which is composed of RF antenna, radar chip and high speed main frequency MCU. It relies on stable and flexible algorithm architecture core to provide solution for scene detections. It's equipped with upper computer or host computer to output detection status and data, and meet several groups of GPIO for user customization and development.

## 2. Theory of operation

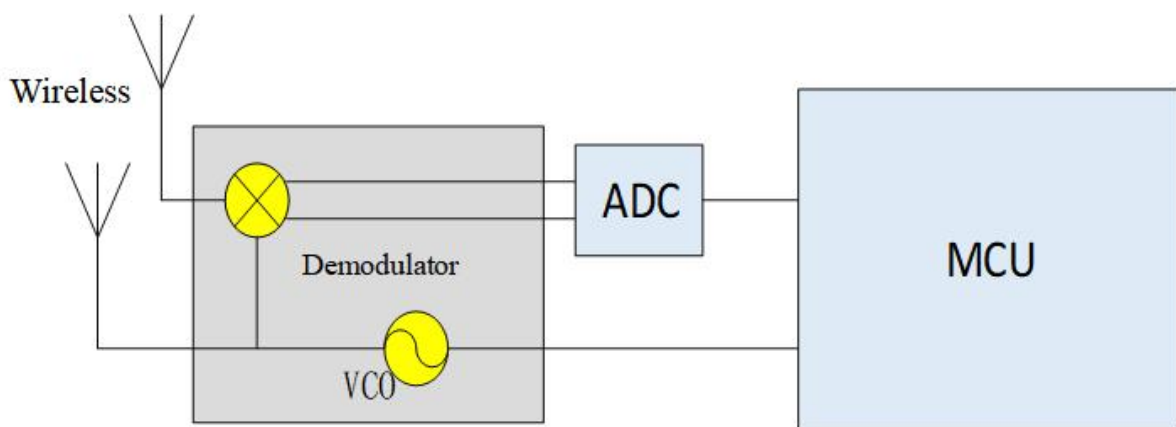

**Figure 1**

The radar transmits 60G band millimeter wave signal, the measured target reflects the electromagnetic wave signal, and demodulates the transmitted signal, which is then amplified, filtered, and processed by ADC to obtain the echo demodulated signal data. Information about the amplitude, frequency, and phase of the echo signal is calculated in the MCU unit, thereby completing target parameter (fall, static stationary, motion, and micro-motion) measurement and scene evaluation.

### 3. Notes for hardware design

The rated supply voltage of this radar shall be 4.9 - 6V, and in normal circumstances, the rated current shall be at least 200mA. Power supply design, power supply ripple shall be  $\leq 100\text{mv}$ .

#### 3.1 For the power supply, refer to the circuit design below

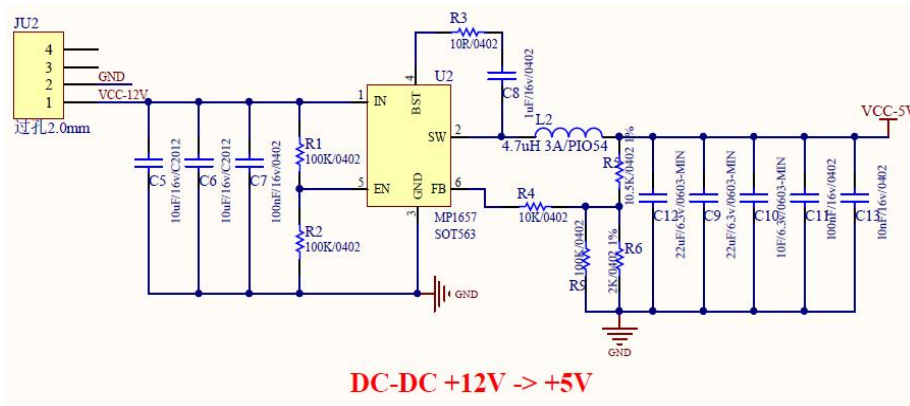

Figure 2

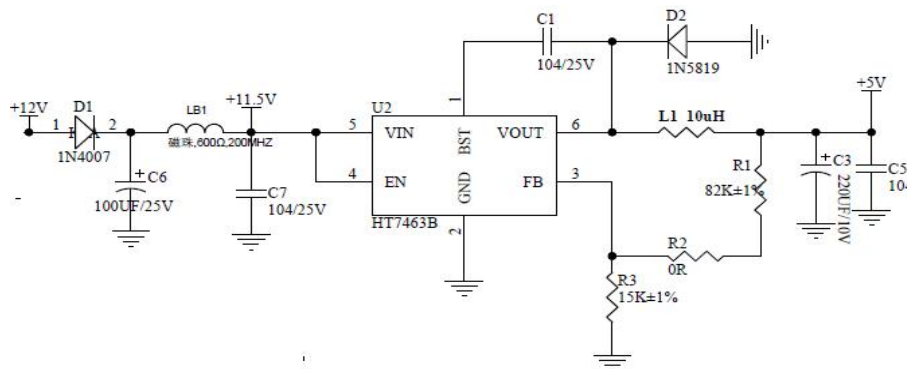

Figure 3

#### 3.2 Application wiring diagram

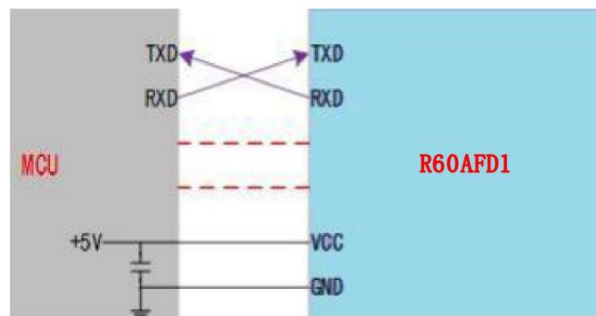

Figure 4 Schematic diagram for connection between radar module and peripherals

## 4. Requirements for antenna and housing layout

PCBA: Mounting height for radar shall be  $\geq 1\text{mm}$  compared with other components

Housing structure: Radar antenna surface and housing surface shall be kept at a distance of 2 - 5mm

Housing detection surface: Non-metallic shell shall be flat, otherwise it may affect the performance of the entire scanning surface

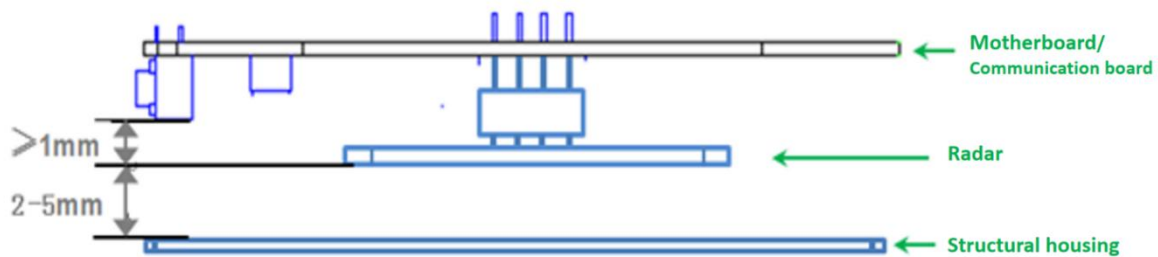

Figure 5

## 5. Electrostatic protection

Radar products contain electrostatic sensitive circuits, and shall be protected from static electricity during transportation, storage, working and picking up. Do not touch the radar module antenna surface and connector pins.

Hold the components by their edge.

When handling the radar sensor, please wear anti-static gloves.

## 6. Function description

### 6.1 Description of function point

Function point	State change time/function explanation
DP1: Presence/Non-presence	Report within 0.5s from non-presence to presence If there is no output in 30s, presence changes to non-presence
DP2: Fall alarm	Report immediately when the radar judges that the fall alarm conditions are met
DP3: Stay-still alarm	Report stay-still alarms under abnormal stay-still for 5min

## 7. Protocol description

This protocol is applied to the communication between the 60G millimeter wave fall detection radar and the host computer.

This protocol outlines the radar workflow, gives a brief introduction to the interface protocol composition architecture, and explains the control commands and data required for radar operation. The serial communication is defined as follows:

- Interface level: TTL
- Baud rate: 115200bps
- Stop bit: 1
- Data bit: 8
- Parity check: N/A

## 8. Definition of communication command and parameter

### 8.1 Definition and description of frame structure

#### Definition of frame structure

Frame	Control word	Command word	Length identification		Data	Check digit	Frame tail
0X53 0X59	Control	Command	Lenth_H	Lenth_H	Data	Sum	0X54 0X43
2 Byte	1 Byte	1 Byte	1 Byte	1 Byte	n Byte	1 Byte	2 Byte

#### Description of frame structure

- Frame header: 2Byte, fixed to 0X53,0X59;
- Control word: 1 Byte  
(0x01-heartbeat packet identification, 0x02-product information, 0x03-OTA upgrade, 0x05-working status, 0X06-installation method, 0x80-human presence, 0X83-fall detection)
- Command word: 1Byte (identification of current data)
- Length identification: 2Byte, equal to the specific byte length of data
- Data: nByte, defined according to the actual function
- Check digit: 1Byte (check digit calculation: (frame header + control word + command word + length identifier + data) take the lowest eight bits after summation)
- Frame end: 2Byte, fixed to 0X54,0X43;

## 8.2 Description of address assignment and data information

Category	Function description	Transmission direction	Frame header	Control word	Command word	Length identification	Data	Verification field	Frame tail	Remarks	
System functions	Heartbeat packet report (1min)	Report	5359	01	01	0001	0F	sum	5443		
	Module reset	Issue	5359	01	02	0001	0F	sum	5443		
		Report	5359	01	02	0001	0F	sum	5443		
<b>Information query</b>											
Product Info	Product model query	Issue	5359	02	A1	0001	0F	sum	5443		
		Reply	5359	02	A1	len	len B product information	sum	5443		
	Product id query	Issue	5359	02	A2	0001	0F	sum	5443		
		Reply	5359	02	A2	len	len B product id	sum	5443		
	Hardware model query	Issue	5359	02	A3	0001	0F	sum	5443		
		Reply	5359	02	A3	len	len B hardware model	sum	5443		
	Firmware version query	Issue	5359	02	A4	0001	0F	sum	5443		
		Reply	5359	02	A4	len	len B firmware version query	sum	5443		
Working status	Message of initialization complete	Report	5359	05	01	0001	0f	sum	5443		
	Upload of radar failure	Report	5359	05	02	0001	00: Working properly 01: Radar chip exception 02: Encryption exception ---	sum	5443		
	Working hours report	Report	5359	05	03	0004	4B working hours	sum	5443	Report method: Report once a minute Value range: 0-0xffffffff Unit: s No specific definition Default report 0x0000000	
	<b>Information query</b>										
	Initialization progress query	Issue	5359	05	81	0001	0F	Sum	5443		
Reply		5359	05	81	0001	01: Completed 00: Not completed	Sum	5443			

Parameter settings										
Radar installation information	Installation angle	Issue	5359	06	01	0x0006	2B X-axis angle + 2B Y-axis angle + 2B Z-axis angle	sum	5443	Height in cm Step length 1cm  Automatic height measurement is an auxiliary function that is susceptible to interference, resulting in inaccurate measurement
		Reply	5359	06	01	0x0006	2B X-axis angle + 2B Y-axis angle + 2B Z-axis angle	sum	5443	
	Mounting height	Issue	5359	06	02	0002	2B height information	sum	5443	
		Reply	5359	06	02	0002	2B height information	sum	5443	
	Automatic height measurement	Issue	5359	83	90	0001	0F	sum	5443	
		Reply	5359	83	90	0002	2B height	sum	5443	
Parameter query										
Installation information query	Installation angle query	Issue	5359	06	81	0001	0F	sum	5443	Installation angle query
		Reply	5359	06	81	0006	2B X-axis angle + 2B Y-axis angle + 2B Z-axis angle	sum	5443	
	Installation height query	Issue	5359	06	82	0001	0F	sum	5443	
		Reply	5359	06	82	0002	2B height information	sum	5443	
Human presence report										
Human presence report	Enable/disable human presence function	Issue	5359	80	00	0001	01: Enable 00: Disable	sum	5443	Report method: Report on status changes  Report method: Report on status changes  Report method: Report every 1s Value range: 0-100  The total quantity of height ratio reaches 100, and the motion is within the range of which height accounts for the largest proportion
		Reply	5359	80	00	0001	01: Enable 00: Disable	sum	5443	
	Human presence information report	Report	5359	80	01	0001	00: Non-presence 01: Presence	sum	5443	
	Movement information report	Report	5359	80	02	0001	00: No 01: Static 02: Active	sum	5443	
	Body movement parameter report	Report	5359	80	03	0001	1B body movement parameters	sum	5443	
	Height proportion report	Report	5359	83	0E	0006	1B: Total quantity of height, high 8 digit 2B: Total quantity of height, low 8 digit 3B: 0-0.5m height proportion 4B: 0.5-1m height proportion	Sum	5443	



							5B: 1-1.5m height proportion 6B: 1.5-2m height proportion			
Trajectory point	Report	5359	83	12	0004	X(2B), Y(2B)	Sum	5443	Refresh time 2s	
Scenario	Report	5359	05	07	0001	00: Scenario	Sum	5443	Default scenario	
Fall detection sensitivity	Report	5359	83	0D	0001	03: Default level	Sum	5443	Adjustable level range 0-3	
Sitting-still horizontal distance setting	Issue	5359	80	0D	0002	2B sitting-still horizontal distance	Sum	5443	Value range: 0-300 Unit: cm	
	Reply	5359	80	0D	0002	2B sitting-still horizontal distance	Sum	5443	Value range: 0-300 Unit: cm	
Moving horizontal distance setting	Issue	5359	80	0E	0002	2B moving horizontal distance	Sum	5443	Value range: 0-300 Unit: cm	
	Reply	5359	80	0E	0002	2B moving horizontal distance	Sum	5443	Value range: 0-300 Unit: cm	
Non-presence time settings	Issue	5359	80	12	0004	4B byte time	Sum	5443	Value range: 5-1800 Unit: S	
	Reply	5359	80	12	0004	4B byte time	Sum	5443	Value range: 5-1800 Unit: S	
<b>Information query</b>										
Human presence switch query	Issue	5359	80	80	0001	0F	sum	5443		
	Reply	5359	80	80	0001	01: Enable 00: Disable	sum	5443		
Presence information query	Issue	5359	80	81	0001	0F	sum	5443		
	Reply	5359	80	81	0001	00: Non-presence 01: Presence	sum	5443		
Movement information query	Issue	5359	80	82	0001	0F	sum	5443		
	Reply	5359	80	82	0001	00: No 01: Static 02: Active	sum	5443		
Body movement parameter query	Issue	5359	80	83	0001	0F	sum	5443	Value range: 0-100	
	Reply	5359	80	83	0001	1B body movement parameters	sum	5443		
Trajectory point information query	Issue	5359	83	92	0001	0F	Sum	5443		
	Reply	5359	83	92	0004	X(2B), Y(2B)	sum	5443		
Trajectory point information report frequency query	Issue	5359	83	93	0001	0F	sum	5443	Value range: 0-0xffffffff Unit: s	
	Reply	5359	83	93	0004	4B duration	sum	5443		
Trajectory point information report switch query	Issue	5359	83	94	0001	0F	sum	5443		
	Reply	5359	83	94	0001	01: Enable 00: Disable	sum	5443		

	Sitting-still horizontal distance query	Issue	5359	80	8D	0001	0F	sum	5443	Value range: 0-300 Unit: cm
		Reply	5359	80	8D	0002	2B sitting-still horizontal distance	sum	5443	
	Moving horizontal distance query	Issue	5359	80	8E	0001	0F	sum	5443	Value range: 0-300 Unit: cm
		Reply	5359	80	8E	0002	2B moving horizontal distance	sum	5443	
	Non-presence time query	Issue	5359	80	92	0001	0F	Sum	5443	Value range: 5-1800 Unit: S
		Reply	5359	80	92	0004	4B byte time	Sum	5443	
<b>Fall detection reporting and setting</b>										
Fall detection reporting and setting	Fall detection switch monitoring function	Issue	5359	83	00	0001	01: Enable 00: Disable	sum	5443	
		Reply	5359	83	00	0001	01: Enable 00: Disable	sum	5443	
	Fall state	Report	0x53 0x59	83	01	0001	00: Not fall 01: Fall	sum	5443	Report method: Report on status changes
	Fall duration setting	Issue	0x53 0x59	83	0C	0004	4B duration	sum	5443	Time range: 5-180s Unit: s
		Reply	0x53 0x59	83	0C	0004	4B duration	sum	5443	
	Stay-still state	Report	0x53 0x59	83	05	0x00 01	00: No stay-still found 01: Stay-still found	sum	5443	Report on state change
	Stay-still duration setting	Issue	5359	83	0A	0004	4B duration	sum	5443	Value range: 60-3600 Unit: s
		Reply	5359	83	0A	0004	4B duration	sum	5443	
	Stay-still switch setting	Issue	5359	83	0B	0001	1B switch	sum	5443	0: Disable 1: Enable
		Reply	5359	83	0B	0001	1B switch 01: Enable 00: Disable	sum	5443	
	Fall detection sensitivity settings	Issue	5359	83	0D	0001	1B Sensitivity	Sum	5443	Value range: 0-3
		Reply	5359	83	0D	0001	1B Sensitivity	Sum	5443	
	Height accumulation time setting	Issue	5359	83	0F	0004	4B duration	Sum	5443	Value range: 0-300 Unit: s
		Reply	5359	83	0F	0004	4B duration	Sum	5443	
	Fall breaking height setting	Issue	5359	83	11	0002	2B (distance)	Sum	5443	Value range: 0-150 Unit: cm
		Reply	5359	83	11	0002	2B (distance)	Sum	5443	
	Height proportion switch setting	Issue	5359	83	15	0001	00: Disable 01: Enable	Sum	5443	
		Reply	5359	83	15	0001	00: Disable 01: Enable	Sum	5443	
Trajectory point information report frequency setting	Issue	5359	83	13	0004	4B duration	Sum	5443	Value range: 0-0xffffffff Unit: s	
	Reply	5359	83	13	0004	4B duration	Sum	5443		

Trajectory point information report switch setting	Issue	5359	83	14	0001	00: Disable 01: Enable	Sum	5443	
	Reply	5359	83	14	0001	00: Disable 01: Enable	Sum	5443	
<b>Information query</b>									
Fall monitoring switch query	Issue	5359	83	80	0001	0F	sum	5443	
	Reply	5359	83	80	0001	01: Enable 00: Disable	sum	5443	
Fall state query	Issue	5359	83	81	0001	0F	sum	5443	
	Reply	5359	83	81	0001	00: Not fall 01: Fall	sum	5443	
Fall duration query	Issue	5359	83	8C	0001	0F	sum	5443	
	Reply	5359	83	8C	0004	4B duration	sum	5443	
Fall breaking height query	Issue	5359	83	91	0001	0F	sum	5443	Value range: 0-150 Unit: cm
	Reply	5359	83	91	0002	2B (height)	sum	5443	
Height proportion switch query	Issue	5359	83	95	0001	0F	sum	5443	
	Reply	5359	83	95	0001	01: Enable 00: Disable	sum	5443	
Stay-still state query	Issue	5359	83	85	0001	0F	sum	5443	
	Reply	5359	83	85	0001	00: No stay-still found 01: Stay-still found	sum	5443	
Stay-still duration query	Issue	5359	83	8A	0001	0F	sum	5443	
	Reply	5359	83	8A	0004	4B duration	sum	5443	
Stay-still switch query	Issue	5359	83	8B	0001	0F	sum	5443	
	Reply	5359	83	8B	0001	1B switch 01: Enable 00: Disable	sum	5443	
Fall detection sensitivity query	Issue	5359	83	8D	0001	0F	Sum	5443	Value range: 0-3
	Reply	5359	83	8D	0001	1B Sensitivity	Sum	5443	
Query of height proportion over a period of time	Issue	5359	83	8E	0001	0F	Sum	5443	The total quantity of height ratio reaches 100, and the motion is within the range of which height accounts for the largest proportion
	Reply	5359	83	0E	0006	1B: Total quantity of height, high 8 digit 2B: Total quantity of height, low 8 digit 3B: 0-0.5m height proportion 4B: 0.5-1m height proportion 5B: 1-1.5m height proportion 6B: 1.5-2m height proportion	Sum	5443	
Height cumulation time query	Issue	5443	83	8F	0001	0F	Sum	5443	Value range: 0-300 Unit: S
	Reply	5443	83	8F	0004	4B duration	Sum	5443	

OTA										
OTA	Start OTA upgrade	Issue	5359	03	01	0013	4B firmware package size + 15B firmware version number	sum	5443	
		Reply	5359	03	01	0004	4B transmission upgrade packet size per frame	sum	5443	The host computer will determine the size of the firmware packet information to be issued per frame according to the reply
	Upgrade package transmission	Issue	5359	03	02	len+4	4B packet offset address + len B packet	sum	5443	
		Reply	5359	03	02	0001	00: Failed to receive 01: Received	sum	5443	
	Stop OTA upgrade	Issue	5359	03	03	0001	01: Firmware package transmission completed 02: Firmware package transmission not completed	sum	5443	
		Reply	5359	03	03	0001	01	sum	5443	

## Appendix 1: Example of data instruction generation

Example: Presence information query:

The data structure for confirming the presence information query according to the protocol form above:

Frame header: 0X53 0X59

Control word: 0X80

Command word: 0X81

Length identification: 0X00 0X01

Data: 0X0F

Check digit: 1Byte (SUM)

Frame end: 0X54 0X43

Combined to a complete command as: 53 59 80 81 00 01 0F sum 54 43

Check digit sum:

$$(0X53+0X59+0X80+0X81+0X00+0X01+0X0F) = 0X01BD$$

Take the lower byte to get sum = 0XBD

So the complete presence information query command is: 53 59 80 81 00 01 0F BD 54 43

## 9.Updates history

Revision	Release Date	Summary
V1.0_0613	2022/06/13	First draft
V1.1_0712	2022/7/12	Improved protocol issues
V1.2_0916	2022/9/16	Added interface protocol for time setting
V1.3_1026	2022/10/26	Added height proportion in Version 1.1.1 and above
V1.4_0307	2023/03/07	Added trajectory points and function interfaces
V1.5_0522	2023/05/22	Improved some protocol details
V1.6_0607	2023/06/07	Added non-presence time setting and query interfaces