

Bio-sensing Universal development board

Development board 24-RADAR-EVB

Instructions (Ver. 1.1)

1.Overview

24-RADAR-EVB is the first version of Micradar 's Demo Board tailored for millimeter-wave radar modules . In order to allow users to experience the performance of radar modules more conveniently and directly, and to allow users to quickly connect into the wireless universal module, both the radar module and the communication module support the pluggable mode, and users can freely adapt to build their own service platform. Also equipped with MCU board-to-interface, users can use their own MCU to communicate with radar and wireless modules respectively.

2 4-RADAR-EVB role:

- **Manufacturer embedded engineer** : use 24-RADAR-EVB for pre-development and debugging of embedded programs
- **Creator** : Use 24-RADAR-EVB to realize hardware product demo, and **cooperate** with communication module to realize project development
- **Technology enthusiasts**: use 24-RADAR-EVB to quickly experience radar principles, output parameters and interface protocols

2.Hardware composition

Power supply input method: Micro USB – DC 5.0V \geq 500mA

Output voltage: DC 5.0V, 3.3V

TTL serial port: can support optional as debug port

Function board interface: radar module, wireless module communication board, MCU board, light sensor board

Others: 1 touch button, 4 indicator lights

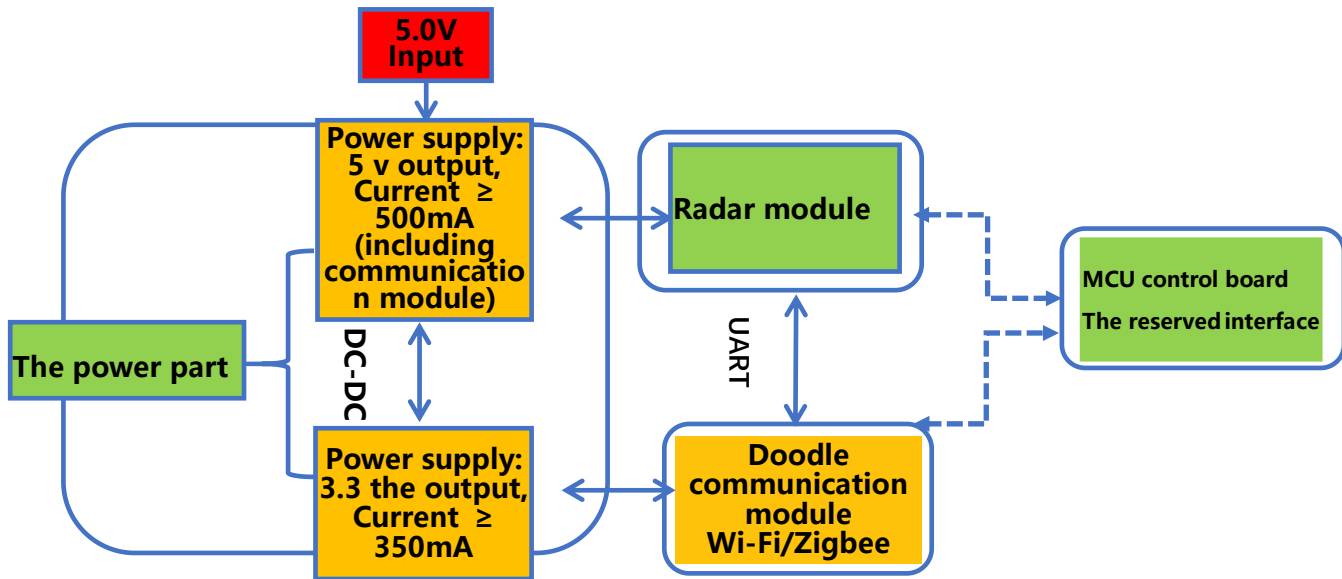

3.Size package

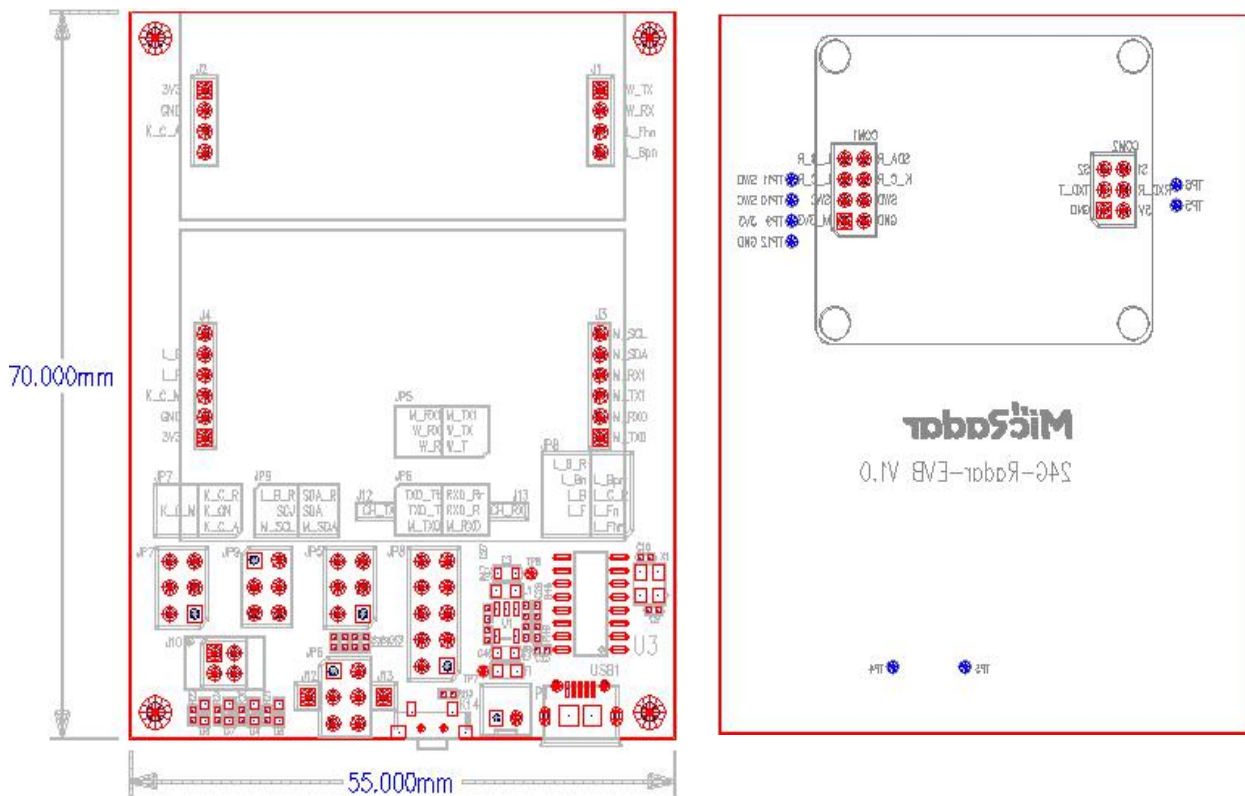

4.Hardware introduction

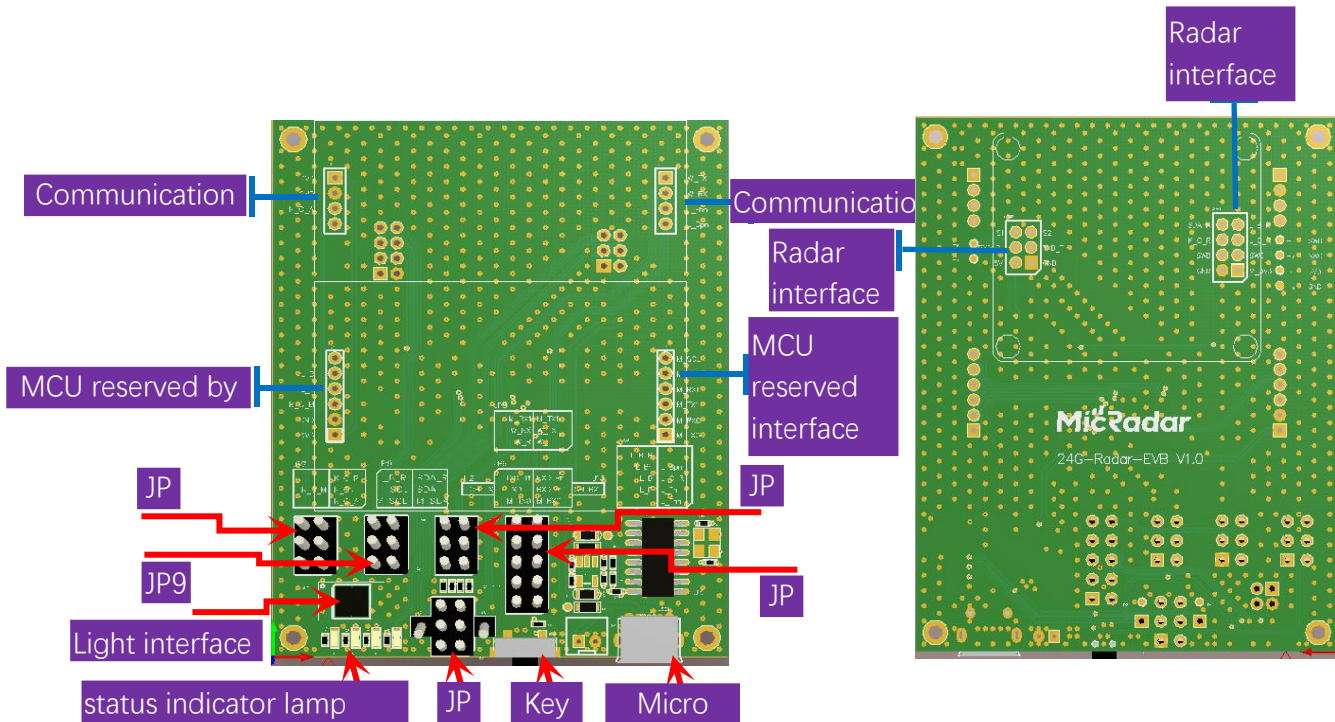

The functions of each interface are described as follows:

1. Communication board interface: 2.0mm single-row female header, respectively, the serial port interface is connected to the MCU interface and the radar interface
2. MCU reserved interface: 2.0mm single-row female header, respectively, the serial port is connected to the communication board and the radar interface
3. Radar interface: 2.0mm female header, standard interface
4. Light sensor interface: BH1710
5. JP5, JP6, JP7, JP8, JP9: jump pins, interface selection
6. Status indicator light: blue light, red light, red light, green light from left to right
7. Button: distribution network trigger or user-defined
8. Micro USB: 5.0V \geq 500mA power supply

5.Schematic Circuit Guide

A. Communication board interface

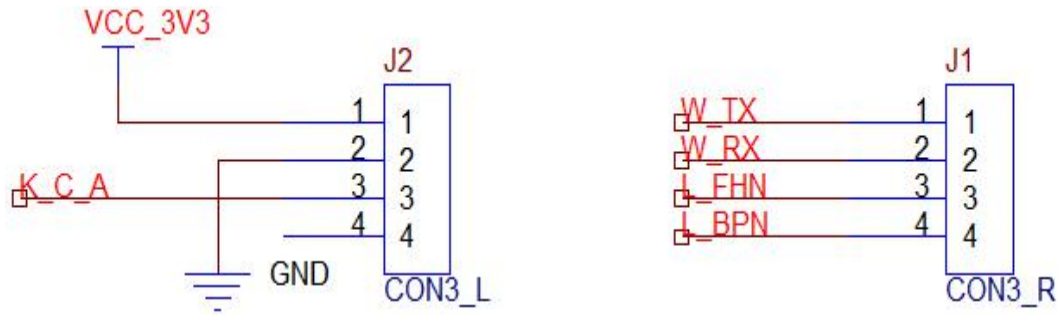

If the silk screen of the board is the same, W_TX and W_RX are the serial ports of the connection module, and L_FHN and L_BPN are the IO of the connection module respectively.

B. MCU interface

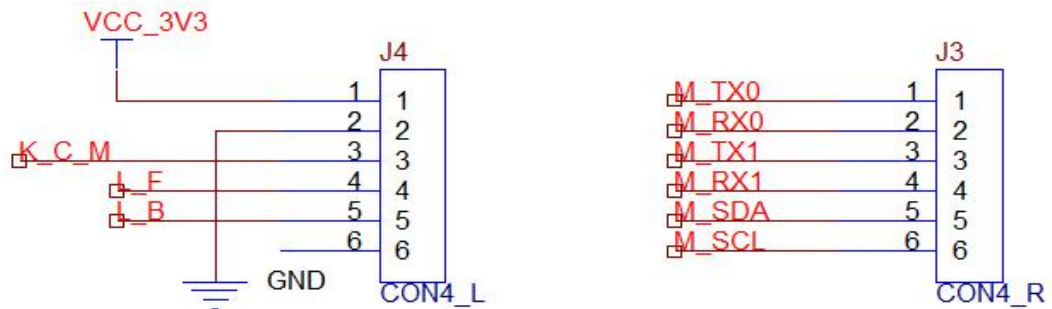

If the silk screen of the board is the same, M_TX0, M_RX0 are MCU serial port 1, M_TX1, M_RX1 are MCU serial port 2, M_SDA, M_SCL are the light sensor driver interface (IIC)

C. Definition of indicator lights

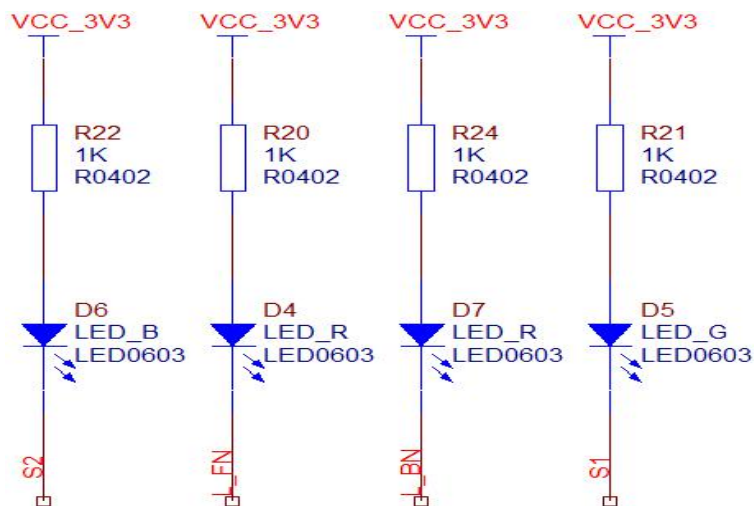

For example, on the front of the board, from left to right, the order is still active, reserved, reserved, and no one is there.

6. Development interface option

A. Radar module interacts with Tuya general module

Connection option: JP 7-K_CN connected to K_C_R button is controlled by radar module IO, long press for 5 s to enter fast network configuration mode

JP8-L_BN to L_B The distribution network indicator is controlled by the radar module IO, and the distribution network mode flashes quickly

JP5-W_T to W_TX W_R to W_RX Tuya module serial port is connected to one end

JP6-TXD_TT to TXD_T RXD_RR to RXD_R The serial port of the radar module is connected to one end

B. MCU interacts with communication module and radar module respectively

Connection option: JP 7-K_C_M connected to K_CN button is controlled by IO of MCU

JP8- L_F connected to L_FN distribution network indicator is controlled by MCU IO

JP6- M_TX0 is connected to TXD_T M_RX0 is connected to RXD_R MCU serial port 0 and radar module interaction

JP5- M_TX1 to W_TX M_RX1 to W_RX The serial port 1 of the MCU interacts with the communication module

C. More free options, users can refer to the schematic diagram to build

7. Historical version update instructions

Revision	Release Data	Summary	Author
V1.0_0728	2021/07/28	first draft	OF_Frank
V1.1_0606	2022/6/6	Adjust the cover of a document	Mark